

Forster Profilsysteme AG
Postfach
CH-9320 Arbon
info@forster.ch
www.forster-profile.ch

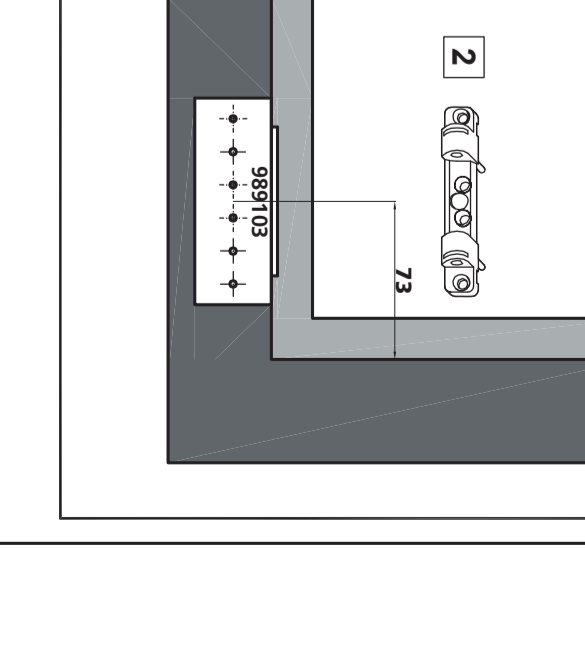
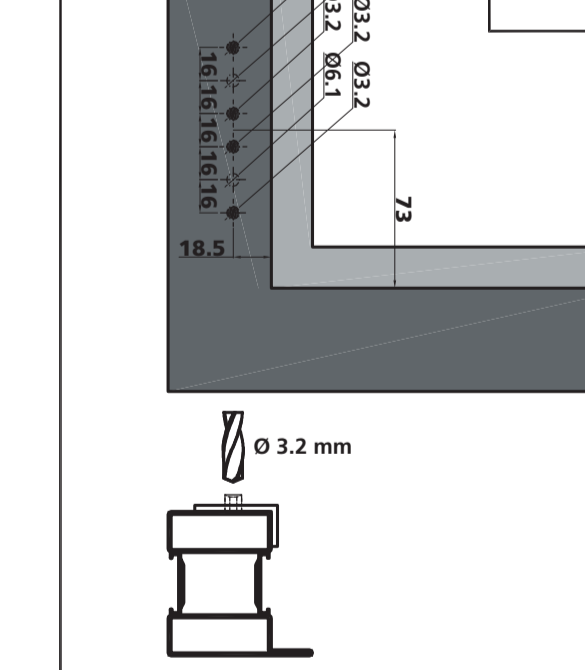
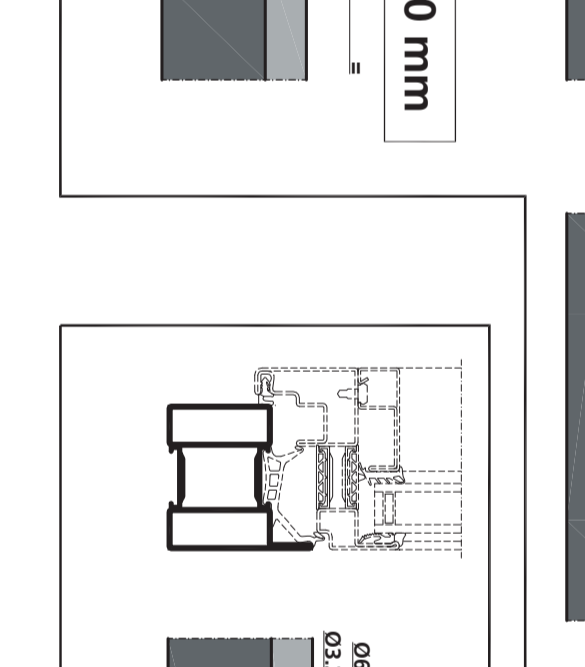
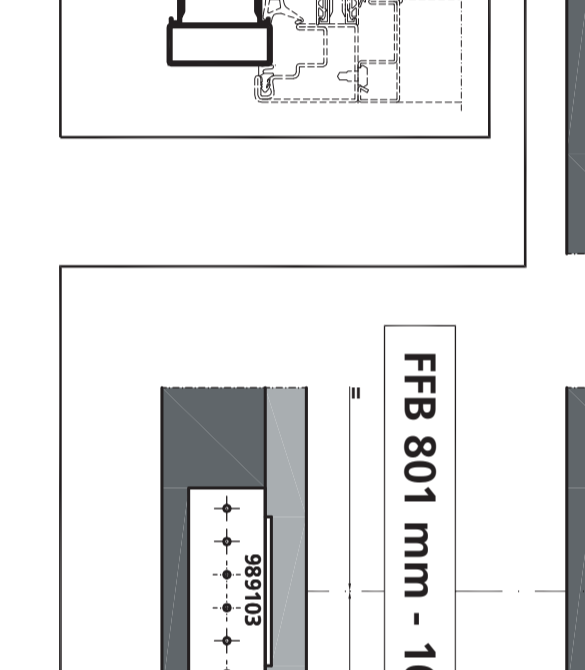
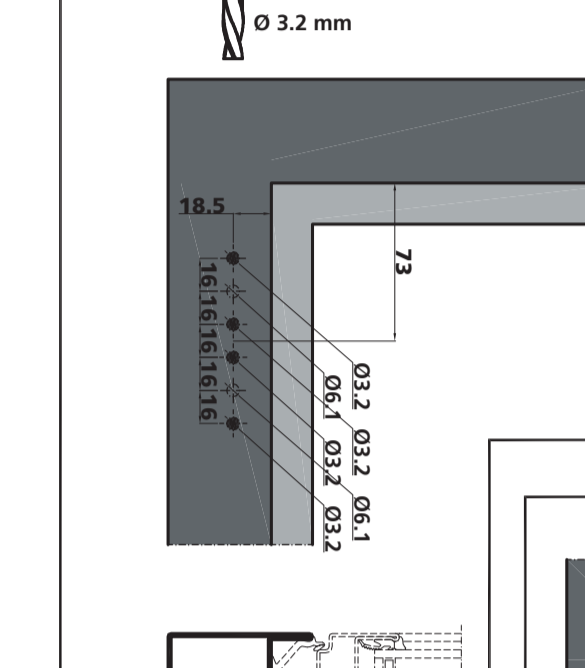
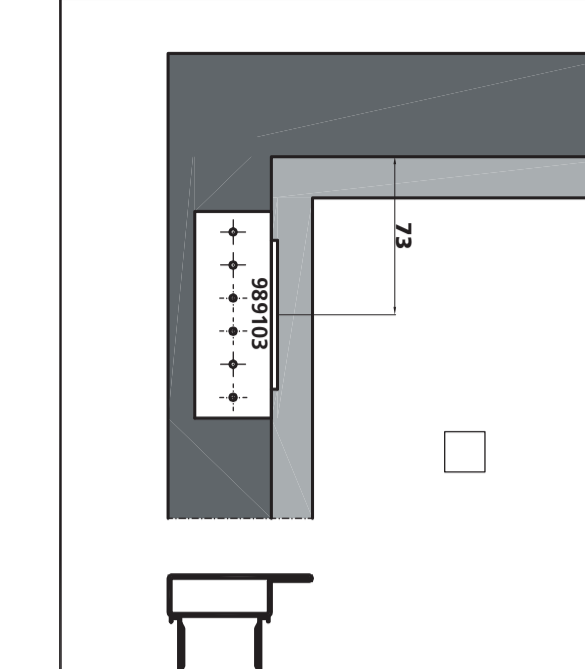
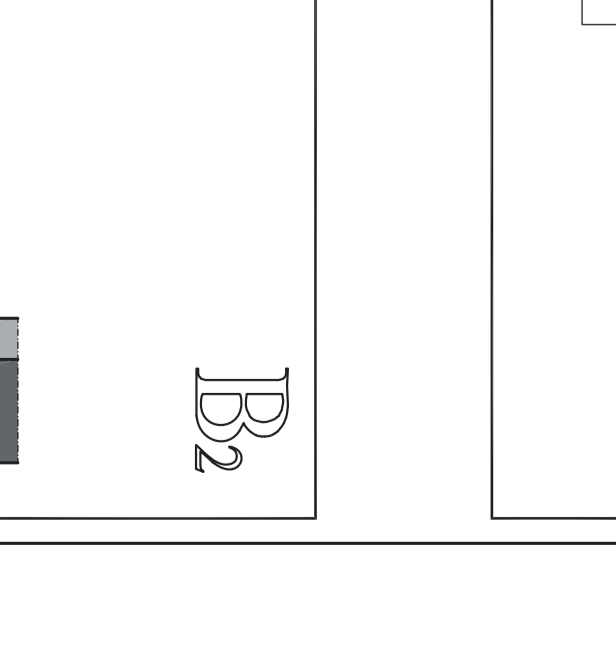
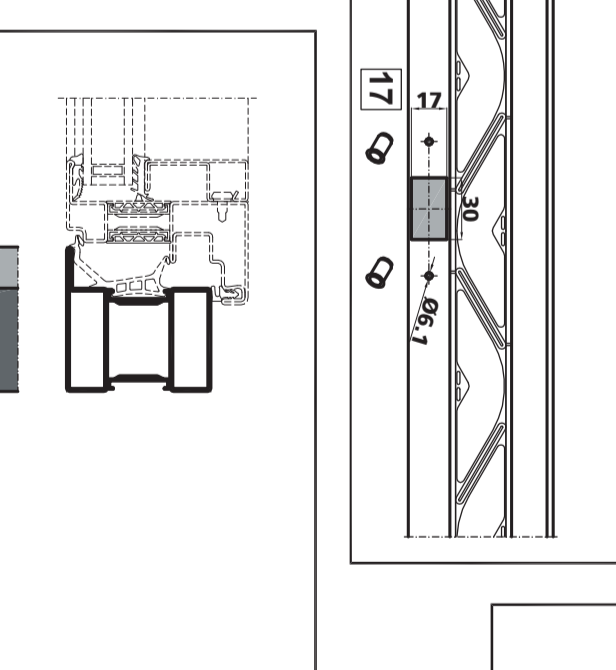
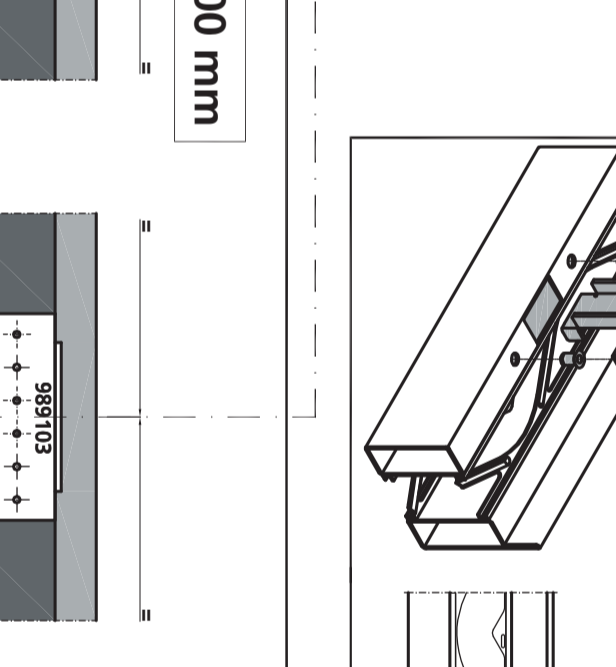
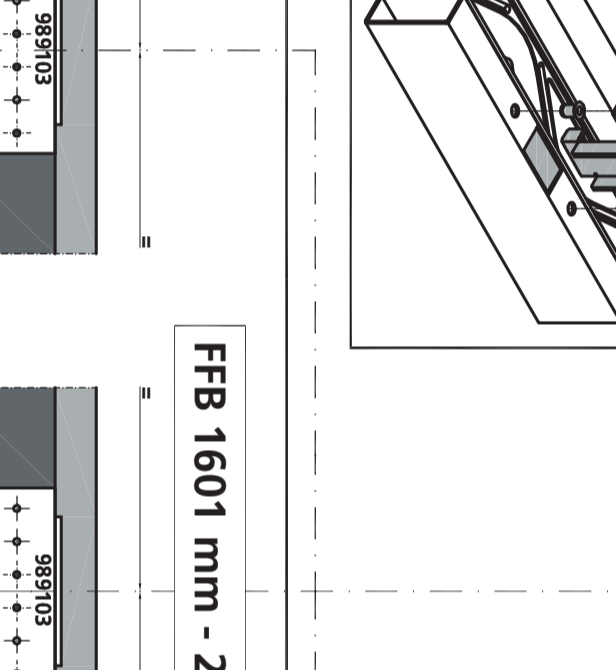
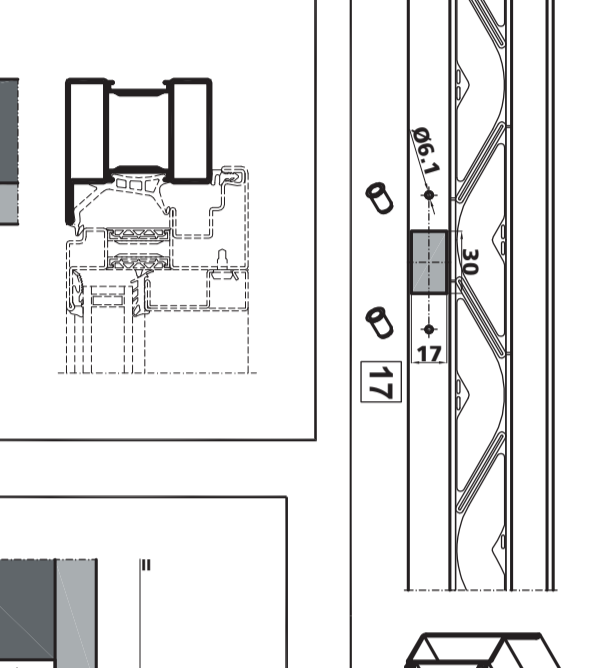
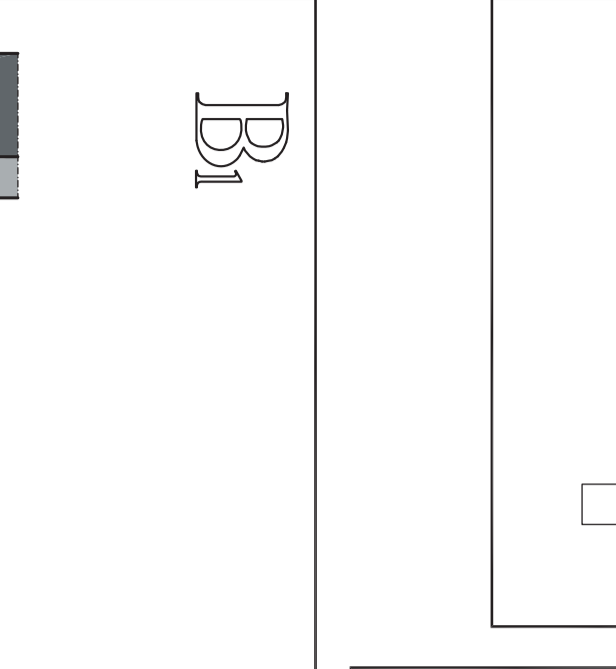
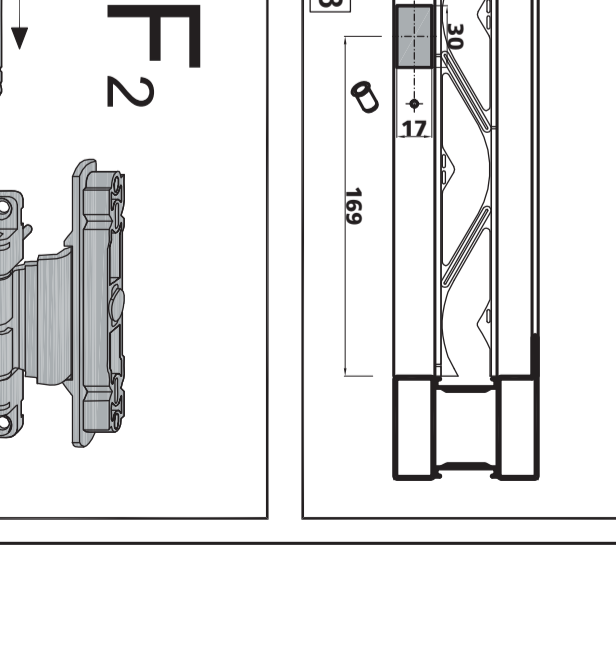
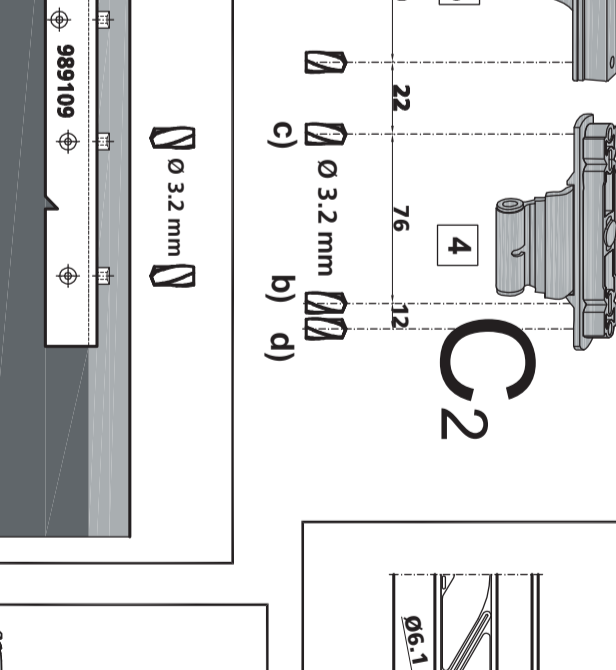
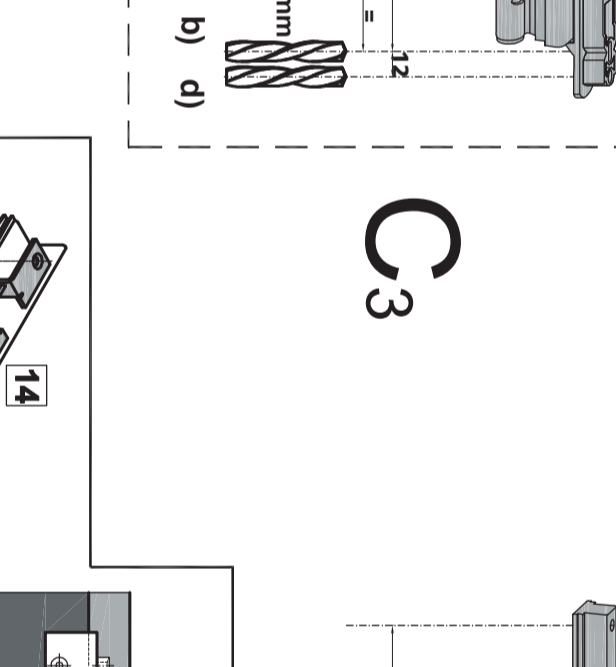
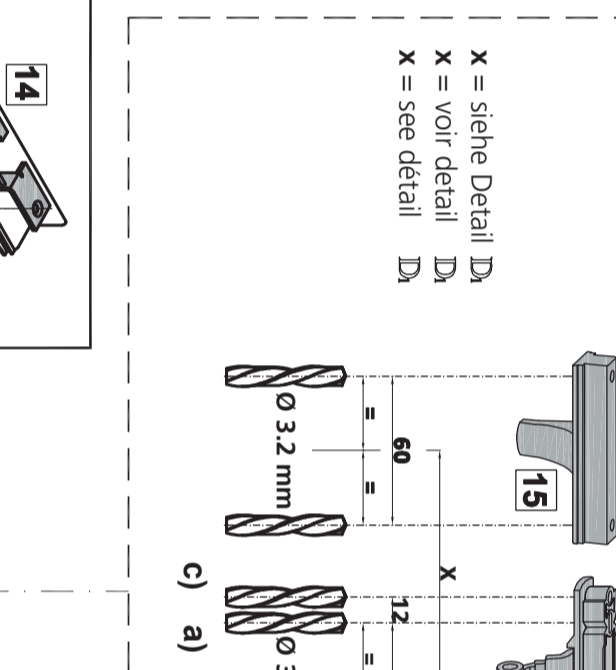
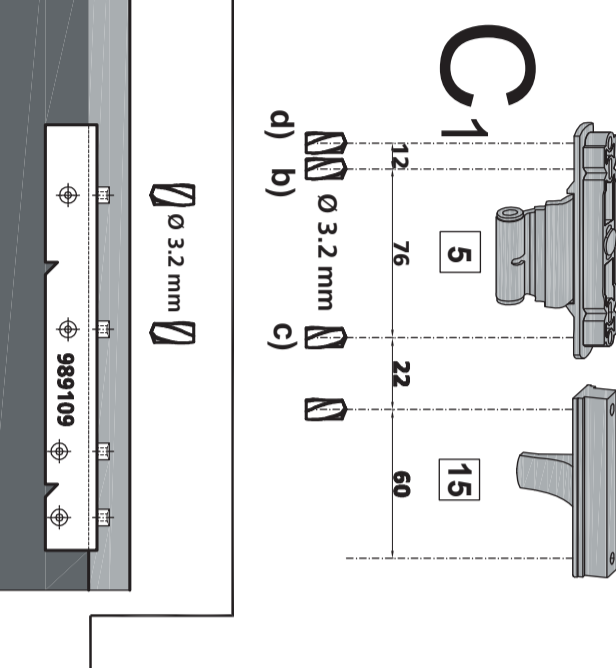
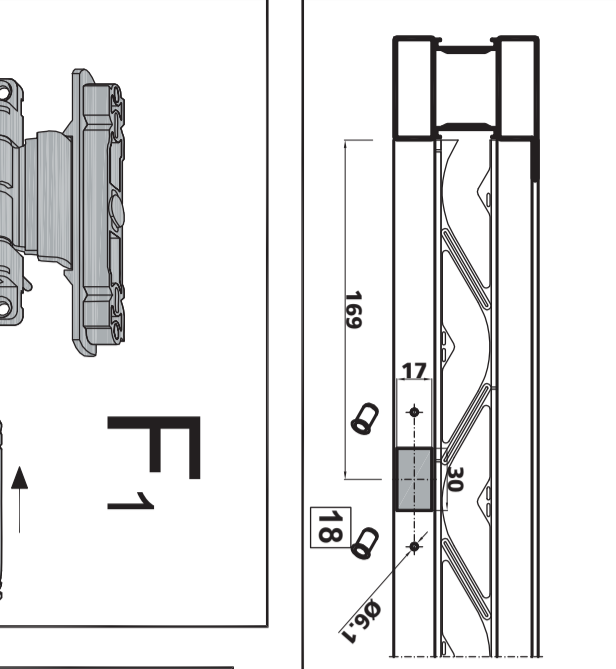
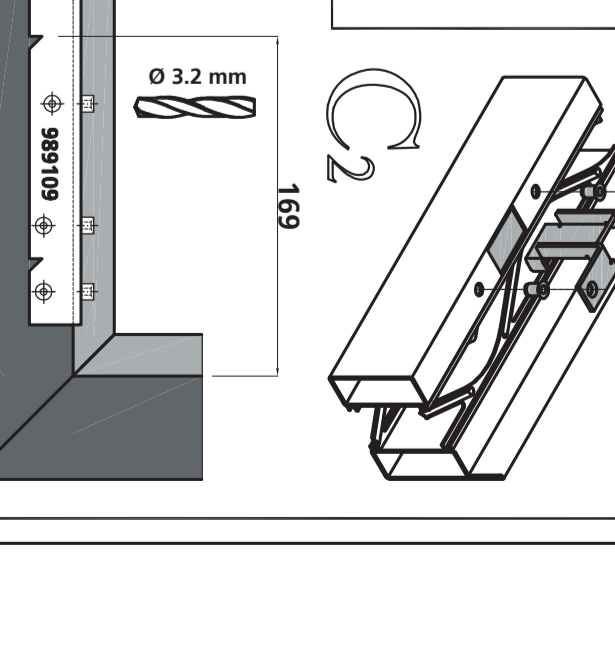
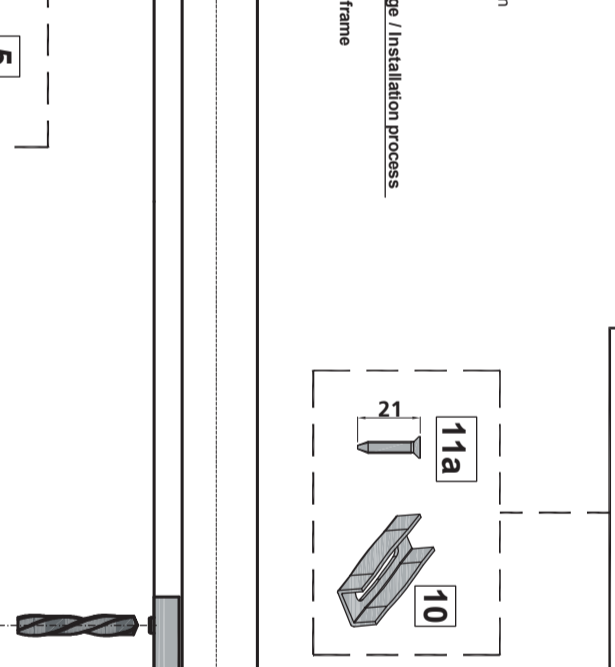
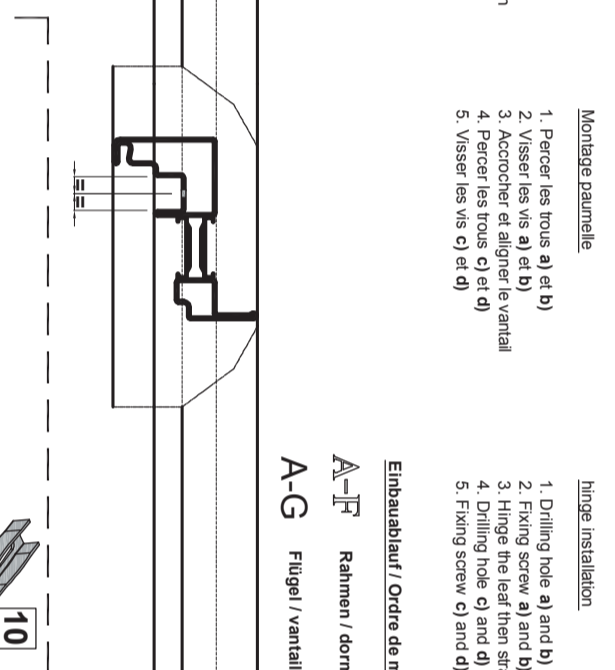
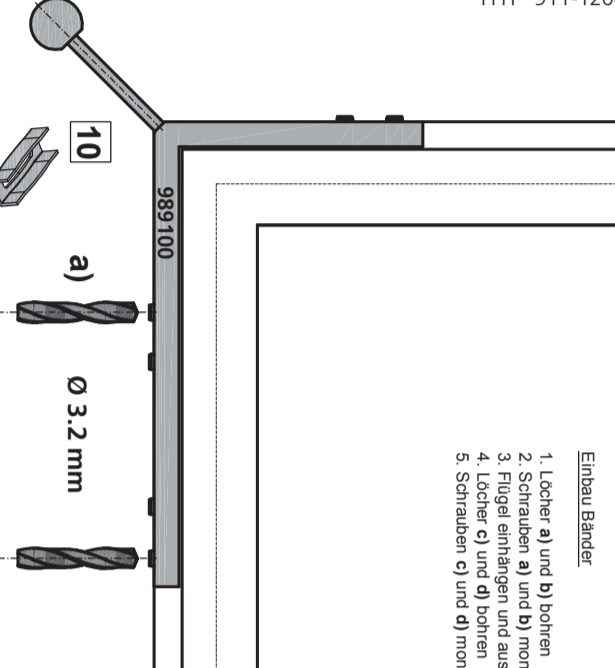
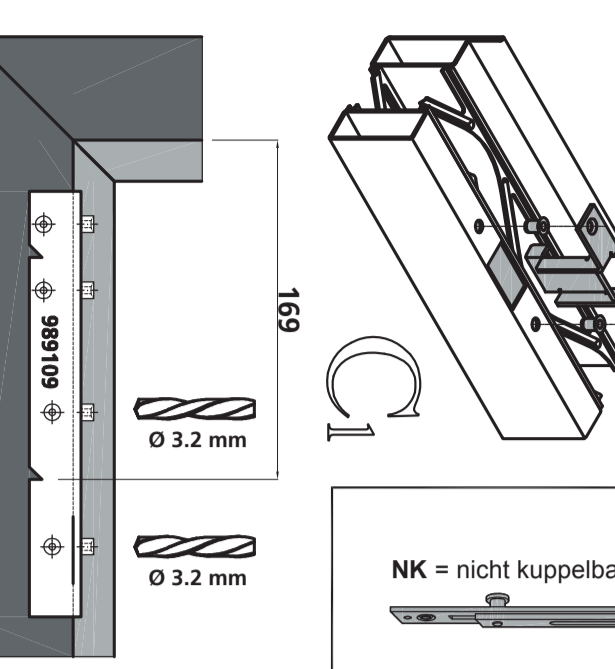
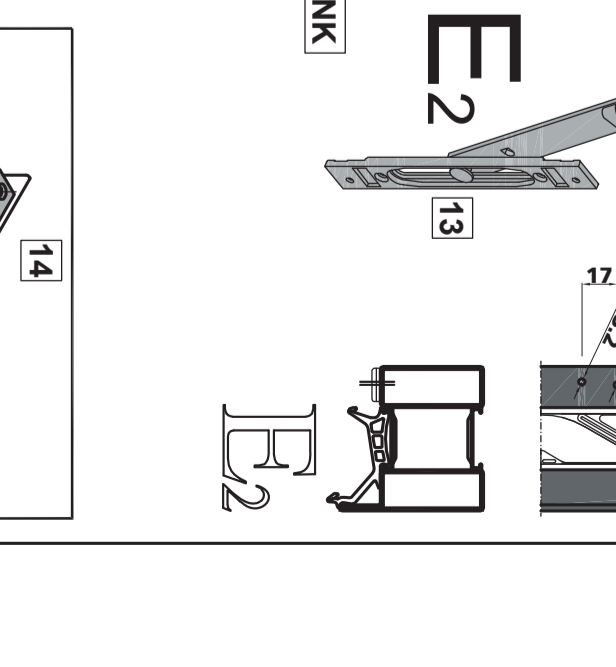
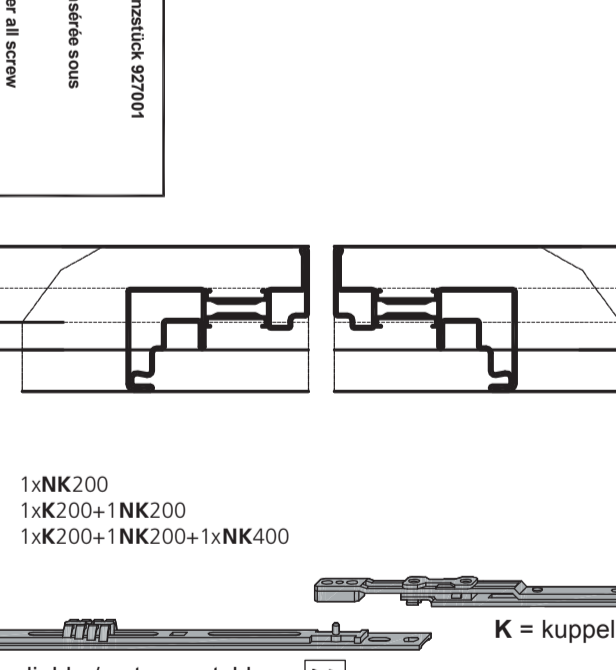
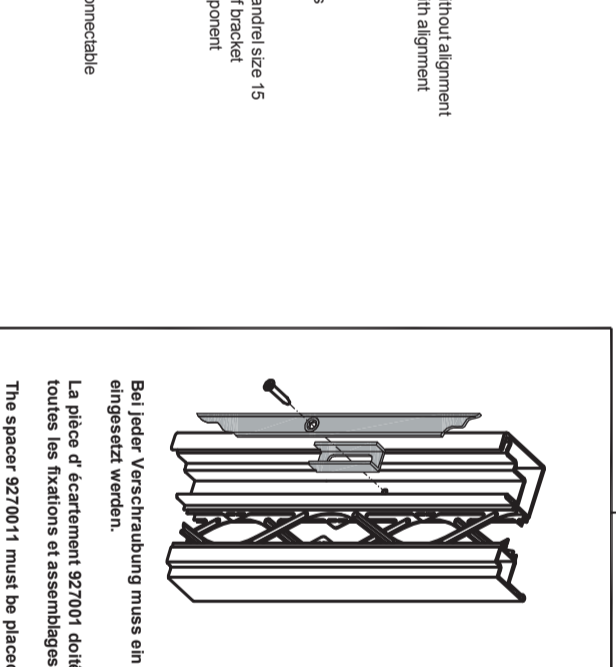
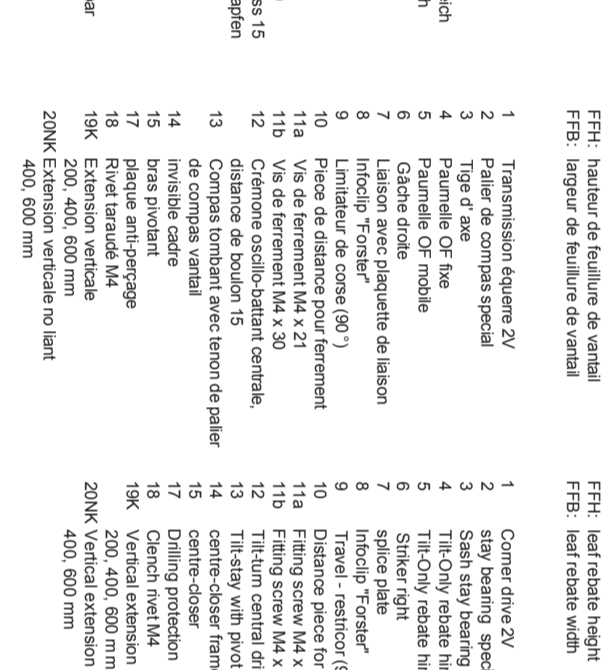
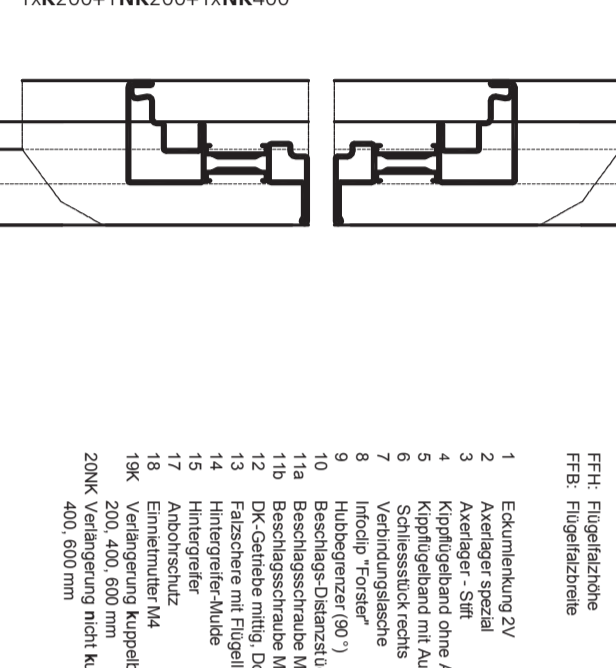
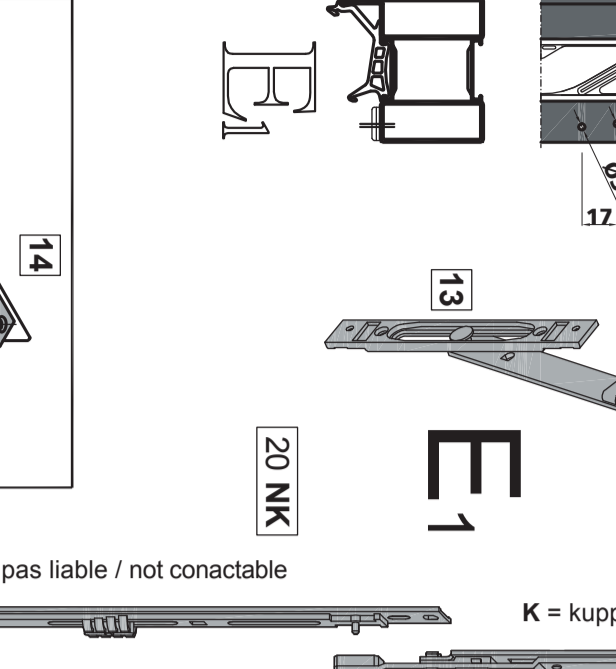
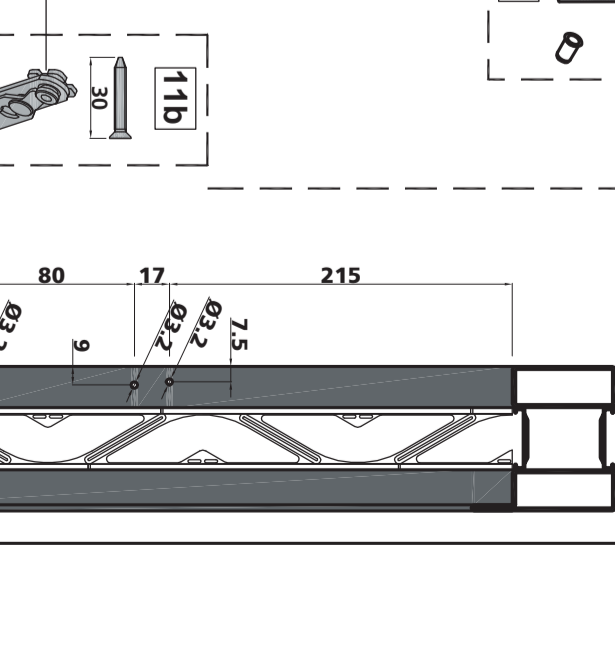
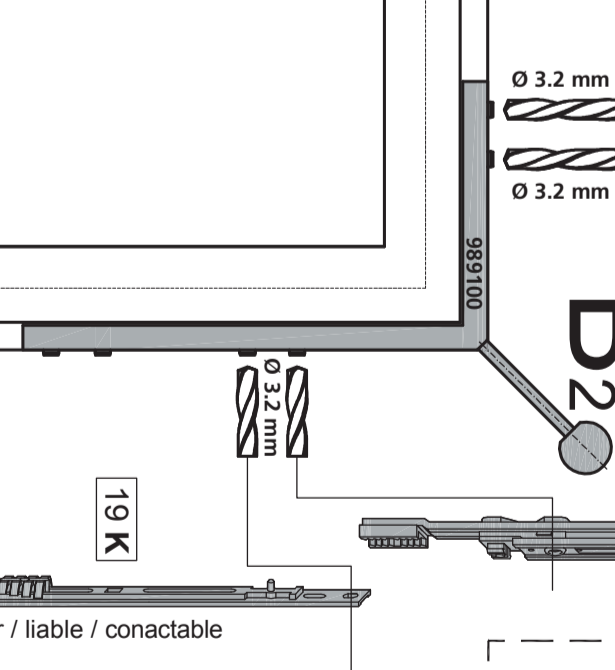
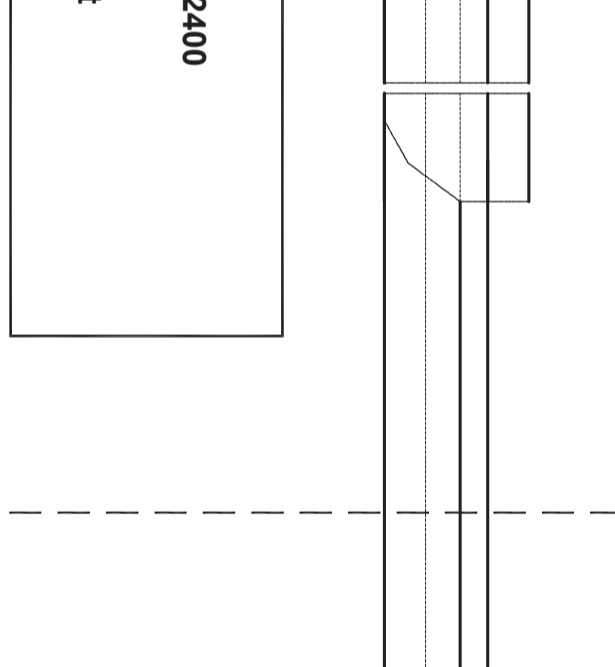
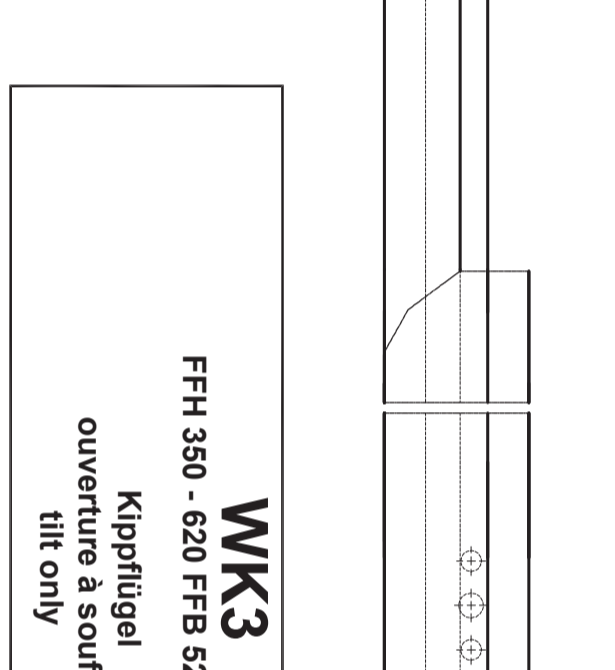
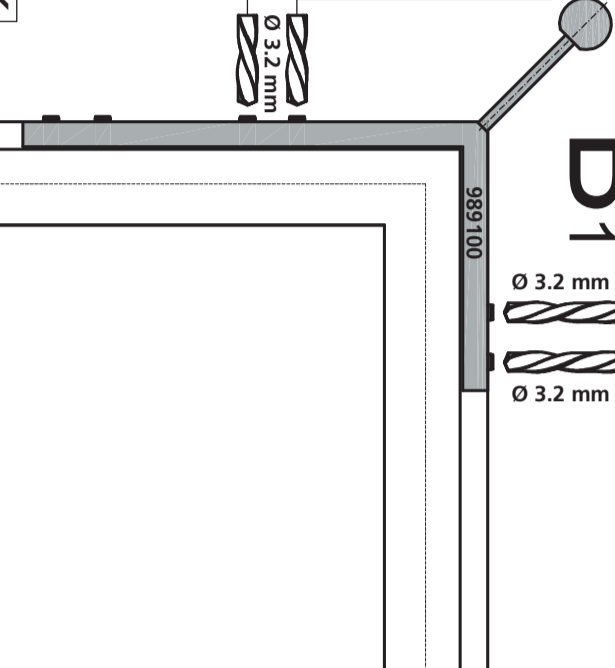
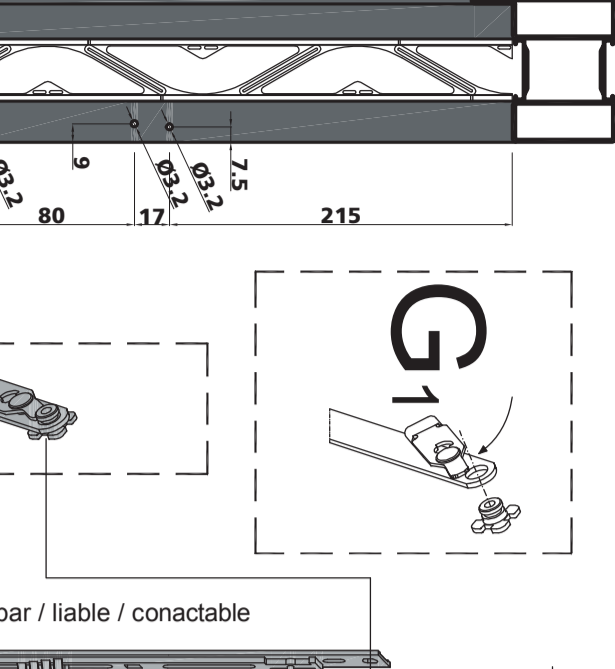
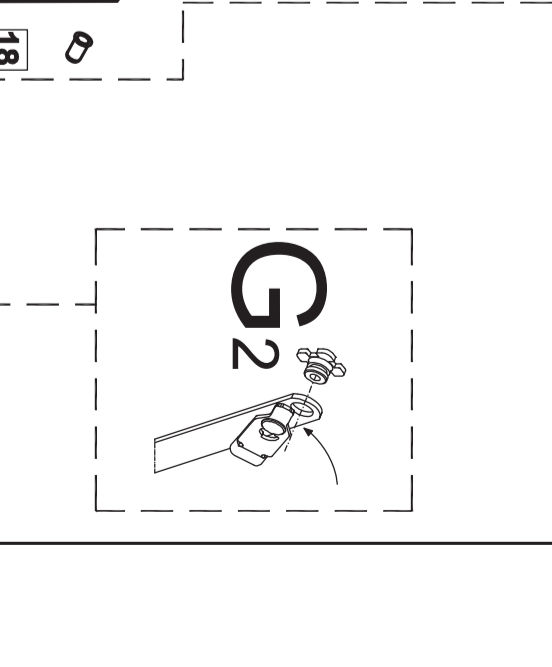
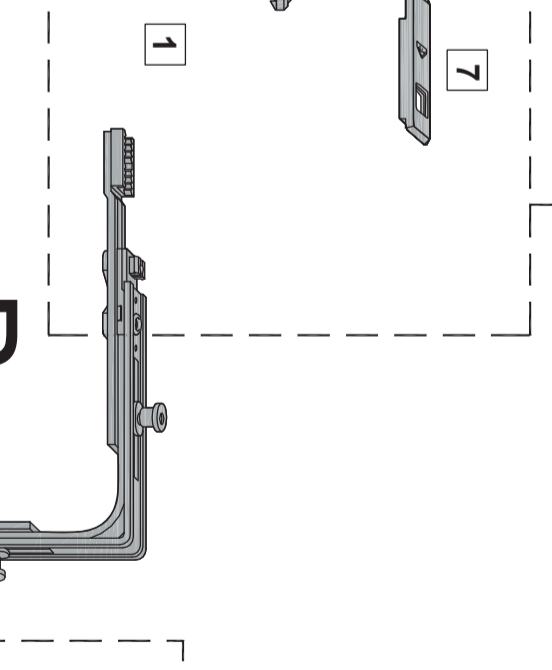
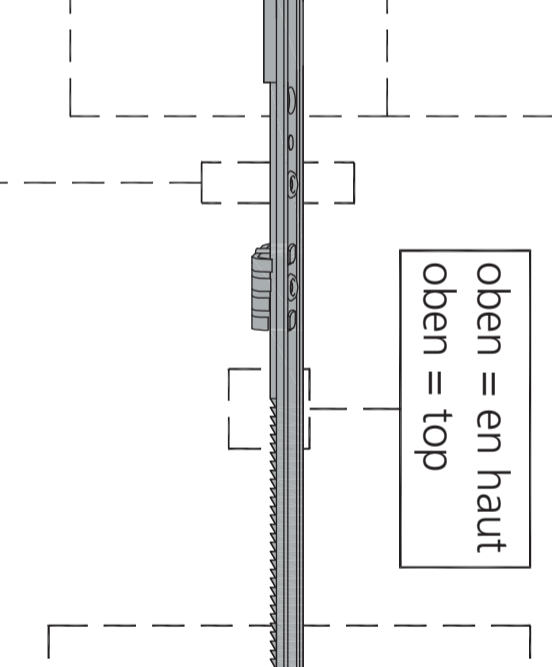
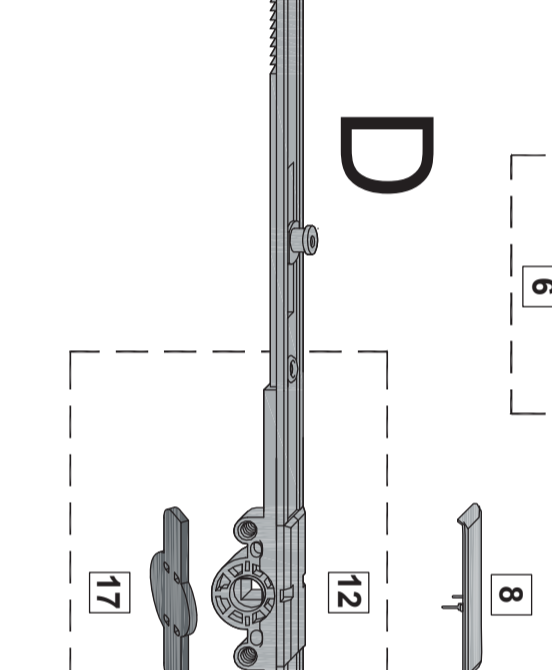
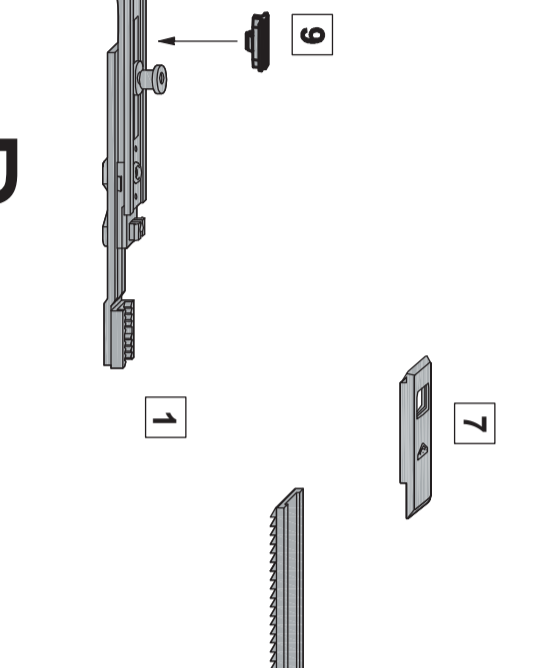
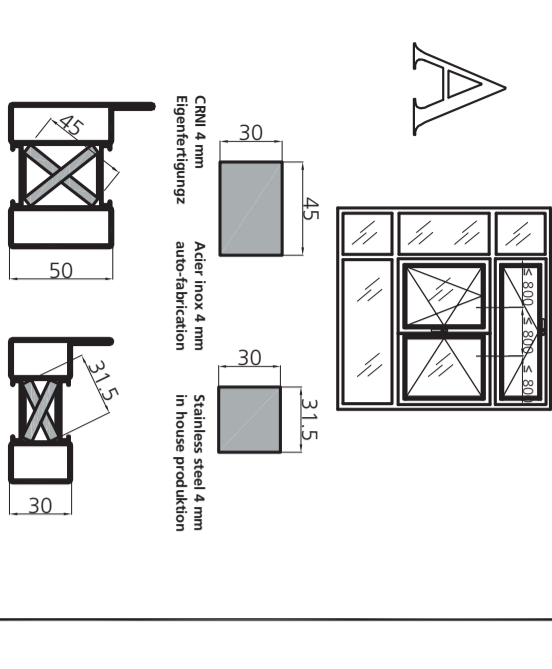
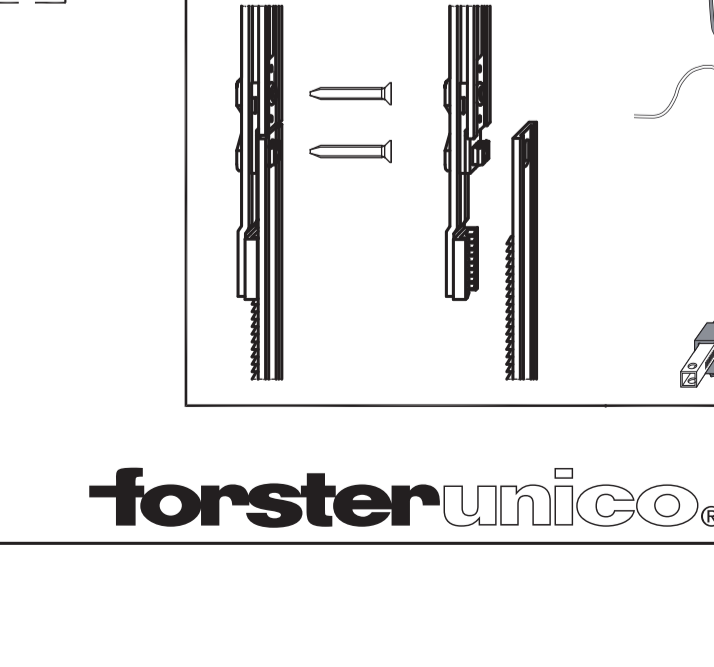
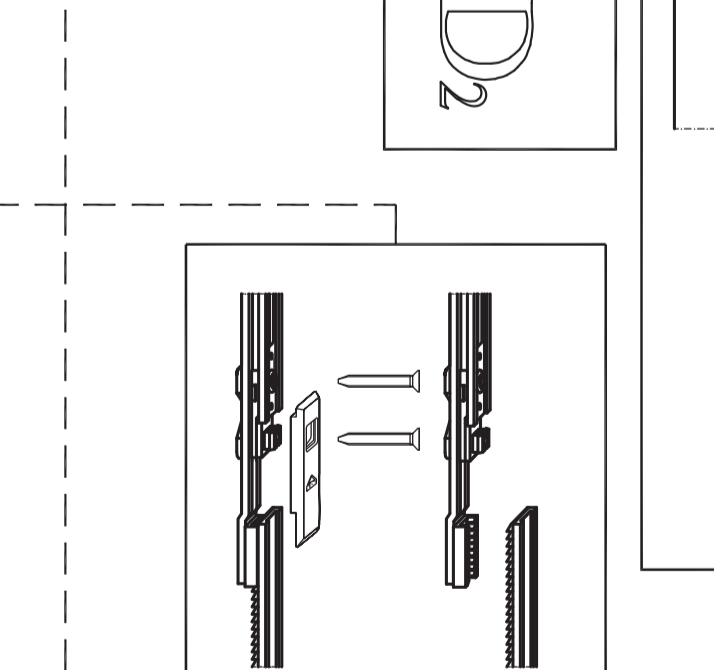
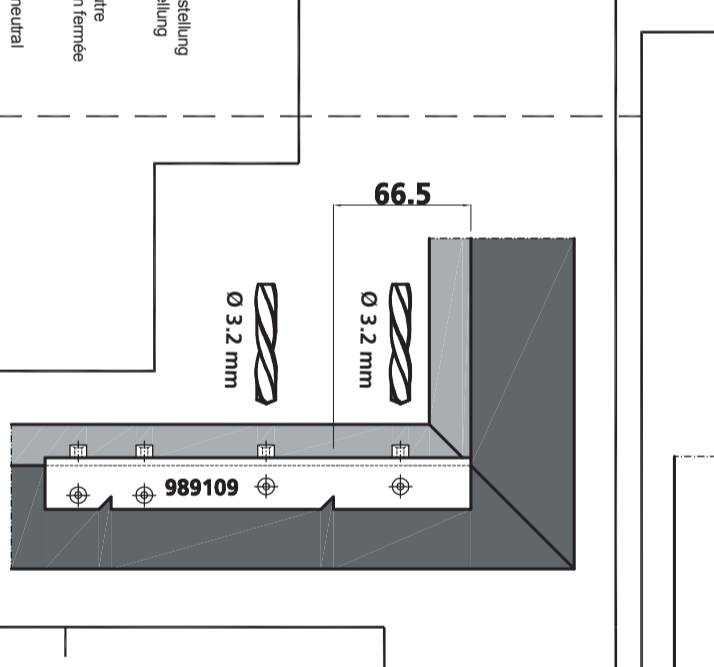
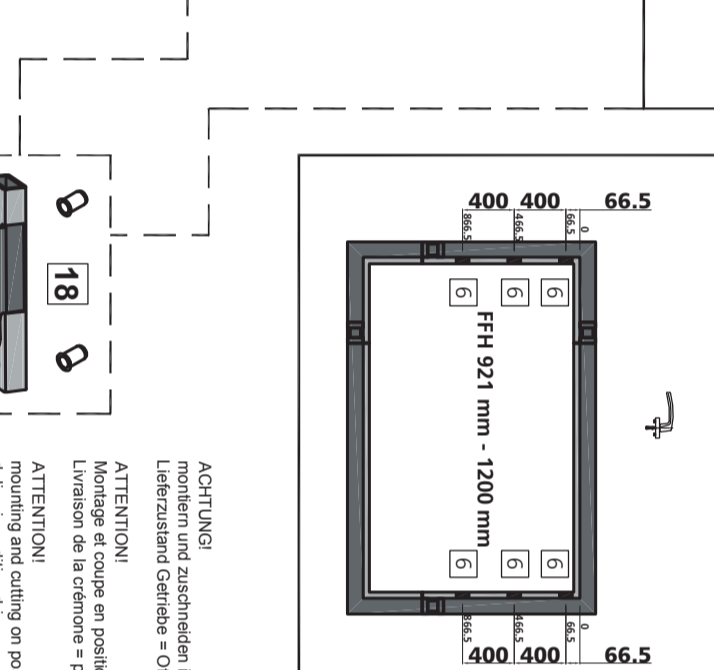
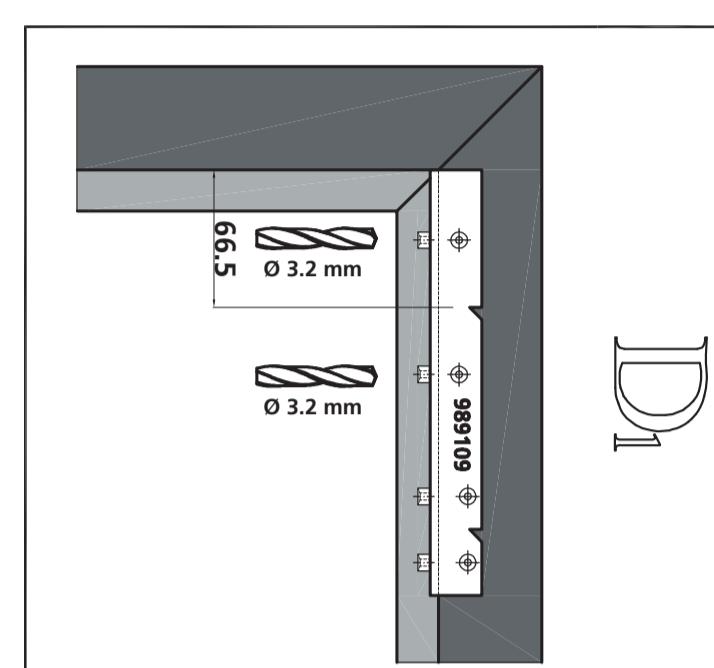
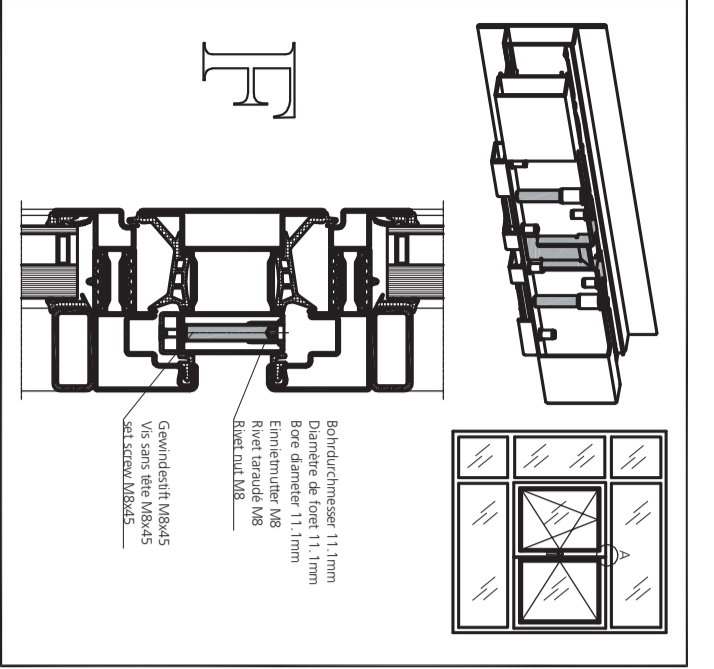

forsterunico

NK = nicht kuppelbar / pas liable / not contactable
K = kuppelbar / liable / contactable

FFH 350-620 1xNK200
FFH 621-910 1xK215
FFH 911-1200 1xK200+1xNK200+1xNK400

FFH 370-620 1xNK200
FFH 621-910 1xK200+1xNK200
FFH 911-1200 1xK200+1xNK200+1xNK400

NK = nicht kuppelbar / pas liable / not contactable
K = kuppelbar / liable / contactable

FFH 370-620 1xNK200
FFH 621-910 1xK200+1xNK200
FFH 911-1200 1xK200+1xNK200+1xNK400

- FFH - Profilfunktionen
1. Eckverankerung ZV
 2. Ankerbolzen - 5/8"
 3. Kippflügelstütze ohne Auslösung
 4. Kippflügelstütze mit Auslösung
 5. Schwenkstopf
 6. Schwenkstopf
 7. Inneputz - Trichter
 8. Inneputz - Trichter
 9. Halbschwenkventil (HÖ)
 10. Halbschwenkventil (HÖ)
 11. Beschlagsschraube M4 x 21
 12. Beschlagsschraube M4 x 21
 13. Beschlagsschraube M4 x 21
 14. Beschlagsschraube M4 x 21
 15. Beschlagsschraube M4 x 21
 16. Beschlagsschraube M4 x 21
 17. Beschlagsschraube M4 x 21
 18. Beschlagsschraube M4 x 21
 19. Beschlagsschraube M4 x 21
 20. Beschlagsschraube M4 x 21

- FFH - Funktion des Bauteils
1. Transmissionsdichtung ZV
 2. Typische Dichtung
 3. Parapanele / CF - Paneel
 4. Parapanele / CF - Paneel
 5. Parapanele / CF - Paneel
 6. Parapanele / CF - Paneel
 7. Parapanele / CF - Paneel
 8. Parapanele / CF - Paneel
 9. Parapanele / CF - Paneel
 10. Parapanele / CF - Paneel
 11. Parapanele / CF - Paneel
 12. Parapanele / CF - Paneel
 13. Parapanele / CF - Paneel
 14. Parapanele / CF - Paneel
 15. Parapanele / CF - Paneel
 16. Parapanele / CF - Paneel
 17. Parapanele / CF - Paneel
 18. Parapanele / CF - Paneel
 19. Parapanele / CF - Paneel
 20. Parapanele / CF - Paneel

- FFH - Profilfunktionen
1. Eckverankerung ZV
 2. Ankerbolzen - 5/8"
 3. Kippflügelstütze ohne Auslösung
 4. Kippflügelstütze mit Auslösung
 5. Schwenkstopf
 6. Schwenkstopf
 7. Inneputz - Trichter
 8. Inneputz - Trichter
 9. Halbschwenkventil (HÖ)
 10. Halbschwenkventil (HÖ)
 11. Beschlagsschraube M4 x 21
 12. Beschlagsschraube M4 x 21
 13. Beschlagsschraube M4 x 21
 14. Beschlagsschraube M4 x 21
 15. Beschlagsschraube M4 x 21
 16. Beschlagsschraube M4 x 21
 17. Beschlagsschraube M4 x 21
 18. Beschlagsschraube M4 x 21
 19. Beschlagsschraube M4 x 21
 20. Beschlagsschraube M4 x 21

- FFH - Funktion des Bauteils
1. Transmissionsdichtung ZV
 2. Typische Dichtung
 3. Parapanele / CF - Paneel
 4. Parapanele / CF - Paneel
 5. Parapanele / CF - Paneel
 6. Parapanele / CF - Paneel
 7. Parapanele / CF - Paneel
 8. Parapanele / CF - Paneel
 9. Parapanele / CF - Paneel
 10. Parapanele / CF - Paneel
 11. Parapanele / CF - Paneel
 12. Parapanele / CF - Paneel
 13. Parapanele / CF - Paneel
 14. Parapanele / CF - Paneel
 15. Parapanele / CF - Paneel
 16. Parapanele / CF - Paneel
 17. Parapanele / CF - Paneel
 18. Parapanele / CF - Paneel
 19. Parapanele / CF - Paneel
 20. Parapanele / CF - Paneel

- FFH - Profilfunktionen
1. Eckverankerung ZV
 2. Ankerbolzen - 5/8"
 3. Kippflügelstütze ohne Auslösung
 4. Kippflügelstütze mit Auslösung
 5. Schwenkstopf
 6. Schwenkstopf
 7. Inneputz - Trichter
 8. Inneputz - Trichter
 9. Halbschwenkventil (HÖ)
 10. Halbschwenkventil (HÖ)
 11. Beschlagsschraube M4 x 21
 12. Beschlagsschraube M4 x 21
 13. Beschlagsschraube M4 x 21
 14. Beschlagsschraube M4 x 21
 15. Beschlagsschraube M4 x 21
 16. Beschlagsschraube M4 x 21
 17. Beschlagsschraube M4 x 21
 18. Beschlagsschraube M4 x 21
 19. Beschlagsschraube M4 x 21
 20. Beschlagsschraube M4 x 21

- FFH - Funktion des Bauteils
1. Transmissionsdichtung ZV
 2. Typische Dichtung
 3. Parapanele / CF - Paneel
 4. Parapanele / CF - Paneel
 5. Parapanele / CF - Paneel
 6. Parapanele / CF - Paneel
 7. Parapanele / CF - Paneel
 8. Parapanele / CF - Paneel
 9. Parapanele / CF - Paneel
 10. Parapanele / CF - Paneel
 11. Parapanele / CF - Paneel
 12. Parapanele / CF - Paneel
 13. Parapanele / CF - Paneel
 14. Parapanele / CF - Paneel
 15. Parapanele / CF - Paneel
 16. Parapanele / CF - Paneel
 17. Parapanele / CF - Paneel
 18. Parapanele / CF - Paneel
 19. Parapanele / CF - Paneel
 20. Parapanele / CF - Paneel

- FFH - Profilfunktionen
1. Eckverankerung ZV
 2. Ankerbolzen - 5/8"
 3. Kippflügelstütze ohne Auslösung
 4. Kippflügelstütze mit Auslösung
 5. Schwenkstopf
 6. Schwenkstopf
 7. Inneputz - Trichter
 8. Inneputz - Trichter
 9. Halbschwenkventil (HÖ)
 10. Halbschwenkventil (HÖ)
 11. Beschlagsschraube M4 x 21
 12. Beschlagsschraube M4 x 21
 13. Beschlagsschraube M4 x 21
 14. Beschlagsschraube M4 x 21
 15. Beschlagsschraube M4 x 21
 16. Beschlagsschraube M4 x 21
 17. Beschlagsschraube M4 x 21
 18. Beschlagsschraube M4 x 21
 19. Beschlagsschraube M4 x 21
 20. Beschlagsschraube M4 x 21

- FFH - Funktion des Bauteils
1. Transmissionsdichtung ZV
 2. Typische Dichtung
 3. Parapanele / CF - Paneel
 4. Parapanele / CF - Paneel
 5. Parapanele / CF - Paneel
 6. Parapanele / CF - Paneel
 7. Parapanele / CF - Paneel
 8. Parapanele / CF - Paneel
 9. Parapanele / CF - Paneel
 10. Parapanele / CF - Paneel
 11. Parapanele / CF - Paneel
 12. Parapanele / CF - Paneel
 13. Parapanele / CF - Paneel
 14. Parapanele / CF - Paneel
 15. Parapanele / CF - Paneel
 16. Parapanele / CF - Paneel
 17. Parapanele / CF - Paneel
 18. Parapanele / CF - Paneel
 19. Parapanele / CF - Paneel
 20. Parapanele / CF - Paneel

- FFH - Profilfunktionen
1. Eckverankerung ZV
 2. Ankerbolzen - 5/8"
 3. Kippflügelstütze ohne Auslösung
 4. Kippflügelstütze mit Auslösung
 5. Schwenkstopf
 6. Schwenkstopf
 7. Inneputz - Trichter
 8. Inneputz - Trichter
 9. Halbschwenkventil (HÖ)
 10. Halbschwenkventil (HÖ)
 11. Beschlagsschraube M4 x 21
 12. Beschlagsschraube M4 x 21
 13. Beschlagsschraube M4 x 21
 14. Beschlagsschraube M4 x 21
 15. Beschlagsschraube M4 x 21
 16. Beschlagsschraube M4 x 21
 17. Beschlagsschraube M4 x 21
 18. Beschlagsschraube M4 x 21
 19. Beschlagsschraube M4 x 21
 20. Beschlagsschraube M4 x 21